

BID REGISTRATION

You MUST register using this form in order to receive notice of any addenda to these documents. Please email the completed form to the Administration Department as soon as possible. It is the vendor's responsibility to verify if addenda have been issued.

Bid Number and Title: 2025-03: Jungle Shores Bike Path Repaving

Receiving Period: May 2, 2025 prior to 2:00 p.m. (Please note that UPS and Fed EX do not guarantee next day delivery before 2:00 pm in this zip code)

Bid Opening: May 2, 2025, 2:00 p.m.

This form is for bid registration only. Please scroll down for additional information.

**BIDDER REGISTRATION
EMAIL THIS FORM IMMEDIATELY TO
maakhus@townofedistobeach.com**

Carefully complete this form and email it to the Administration Department. You must submit one form for each bid being registered.

Company Name: _____

Contact Person: _____

Mailing Address: _____

City: State: Zip Code: _____

Phone: Fax: E-mail: _____

Cut along the outer border and affix this label to your sealed bid envelope to identify it as a "Sealed Bid." Be sure to include the name of the company submitting the bid where requested.

SEALED BID • DO NOT OPEN

SEALED BID NO.: 2025-03

BID TITLE: Bike Path Repaving

DUE DATE/TIME: May 2, 2025, prior to 2:00 PM

SUBMITTED BY: _____
(Name of Company)

DELIVER TO: Town of Edisto Beach
Administration Department
2414 Murray Street
Edisto Beach, South Carolina 29438



**Town of Edisto Beach
Administration Department
Mark Aakhus
RFP #2025-03**

Bike Path Repaving – Jungle Shores

The Town of Edisto Beach is soliciting sealed bids from a licensed contractor to repave the Jungle Shores Bike Path in the Town of Edisto Beach, South Carolina.

Sealed bids will be received in the Administration Department, **prior to 2:00 p.m., May 2, 2025**. Bids will be opened at 2:00 p.m., May 2, 2025.

Attached are important instructions and specifications regarding responses to this Bid. Failure to follow these instructions could result in Bid disqualification.

Bids may be mailed, express mailed, or hand delivered to:

**Town of Edisto Beach
Administration Department
2414 Murray Street
Edisto Beach, South Carolina 29438
(843) 869-2505**

TABLE OF CONTENTS

| <u>Item</u> | <u>Page</u> |
|---|-------------|
| Bid Summary and Registration | 1 |
| Sealed Bid Label | 2 |
| Cover Sheet | 3 |
| Table of Contents | 4 |
| Bidder Instructions and General Information | 5-8 |
| Special Information | 9-10 |
| Scope of Work | 11 |
| Additional Information | 12 |
| Bid Sheet | 13 |
| Addendum Sheet | 14 |
| Insurance | 15 |
| Sample Agreement | 16-20 |
| Appendix A | 21-29 |

BIDDER INSTRUCTIONS AND GENERAL INFORMATION

BIDDER INSTRUCTIONS: To ensure acceptance of this bid, follow these instructions.

BID DOCUMENTS MUST BE DELIVERED TO THE ADMINISTRATION DEPARTMENT PRIOR TO 2:00 P.M. ON THE DATE SPECIFIED. THERE WILL BE NO EXCEPTIONS.

1. **EXECUTION OF BID:** Bid must contain an original signature of an authorized representative in the space provided on the signature page. Bid must be typed or printed in black ink. Erasable ink is not permitted. Corrections made by bidder to any bid entry must be initialed by the person who signs the bid.
2. **BID OPENING:** It is the responsibility of the bidder to assure that their bid is delivered at the proper time and place prior to the bid opening. All bid openings shall be public, at 2:00 p.m., on the date specified in the Notice to Bidders. Bids, which for any reason are not so delivered, will not be considered. **BID SUBMITTAL FORMS USING FACSIMILE OR EMAIL WILL NOT BE ACCEPTED.**
NOTE: Bidders may call the Administration Department for bid results. The telephone number is (843) 869-2505 extension 212. Bid files may be examined during normal working hours by appointment.
3. **TAXES:** Bidders are responsible for the payment of any applicable taxes that are connected to the purchase of any materials or subcontractors used in the execution of this bid.
4. **MISTAKES:** Bidders are required to examine the specifications, delivery schedule, bid prices and all instructions pertaining to the requirements of this bid. Failure to do so will be at bidder's risk. In case of a mistake in extension of a unit price, the unit price will govern. Corrections made by bidder to any bid entry must be initialed by the person who signs the bid.
5. **INVOICING AND PAYMENT:** The successful bidder shall submit a properly certified invoice to the Town at the prices bid. **An original invoice shall be submitted to the Town of Edisto Beach, Administration Department, at 2414 Murray Street, Edisto Beach, South Carolina, 29438.** The vendor shall include the bid number and/or the purchase order number on all invoices. Invoices will be processed for payment when approved by the user department.
6. **CONFLICT OF INTEREST:** All bidders must disclose, with their bid, the name of any officer, director or agent who is also an employee of the Town or any of their agencies. Furthermore, all bidders must disclose the name of any Town employee who owns, directly or indirectly, any interest of any amount in the bidder's firms or any of their branches.
7. **WARRANTY:** Unless otherwise specified, the bidder agrees that the services furnished under this bid shall be covered by the most favorable commercial warranty the bidder gives to any customer for comparable services, and that the rights and remedies provided herein are in addition to and do not limit any rights afforded to the Town by any other provision of this bid. Regardless, all projects are warrantied for one year from date of completion.

8. **ADDENDUM:** Any changes in the bid shall be made in the form of a written addendum by the User Department. No other person shall be authorized to make changes verbally or in writing. If an addendum is issued, the addendum sheet must be signed by the bidder and emailed to maakhus@townofedistobeach.com.
9. **LIABILITY:** The vendor shall hold and save the Town, its officers, agents and employees harmless from liability of any kind in the performance of this bid and against claims by third parties resulting from the supplier's breach of contract or the supplier's negligence.
10. **PATENTS AND ROYALTIES:** The bidder, without exception, shall indemnify and save harmless the Town and its employees from liability of any nature or kind, including cost and expenses for, or on account of, any copyrighted, patented or non-patented invention, process, or article manufactured and used in the performance of this bid. If the bidder uses any design, device or material covered by letters, patent or copyright, it is mutually agreed and understood without exception that the bid prices shall include all royalties or cost arising from the use of such design, device or material in any way involved in the work.
11. **SEALED BIDS:** All bid submittals must be completed and submitted in a sealed parcel. **(DO NOT INCLUDE MORE THAN ONE BID SUBMITTAL PER ENVELOPE. BID SUBMITTAL SHALL INCLUDE ONE (1) ORIGINAL)** The **Original** bid submittal(s) shall be submitted on the forms provided by the Town of Edisto Beach. All bids are subject to the conditions herein; failure to comply will subject bid to rejection.

GENERAL INFORMATION

1. **DEFINITIONS:** The term "Town" means the Town of Edisto Beach, South Carolina, and its authorized designees, agents or employees.
2. **AWARD(S):** The award of this bid shall be based on low bid meeting specifications and other criteria as specifically called out in this document. As the best interest of the town may require, the right is reserved to make award(s) by individual item, group of items or as indicated in the bid form; to reject all bids or waive any minor irregularities or technicalities in bids received. The Town will not accept the bid of vendors or contractors who are delinquent in the payment of taxes, licenses, or any other money due by them to the Town. This solicitation does not commit the Town to award a vendor or to pay for any costs incurred in the preparation of the bid; or to procure or contract for any articles of goods or services. In determining the lowest responsive and responsible bidder, in addition to price, the following may be considered:

The ability, capacity, equipment and skill of the bidder to fulfill the contract. Whether or not the bidder can fulfill the contract within the time specified, without delay or interference. The character, integrity, reputation, judgment, experience and efficiency of the bidder. The previous and existing compliance by the bidder with laws and ordinances relating to the contract. The sufficiency of the financial resources to fulfill the contract to provide the goods and/or services. The quality, availability and adaptability of the suppliers or contractual services to the particular use required. The ability of the bidder to provide future maintenance and service, as required or needed. The number and scope of conditions attached to the bid. Whether the bidder has failed to fully perform prior contracts to the Town's satisfaction, or is past due, delinquent, or owes the Town any money of any type.

3. **NON-CONFORMANCE TO BID CONDITIONS:** Services not delivered as per delivery date in bid and purchase order may result in bidder being found in default, in which event any and all re-procurement costs may be charged against the defaulting vendor. This non-conformance to bid conditions may result in immediate cancellation of the purchase order.
4. **ASSIGNMENT:** Any contract issued pursuant to this bid and the monies which may become due herein is not assignable except with the prior written approval of the Town Administrator.
5. **DISPUTES:** In the event of any doubt or difference of opinion as to the methods provided herein, or the level of performance rendered, the decision of the user department director shall be final and binding on both parties.
6. **PLACING OF ORDERS:** The award of this bid does not constitute an order. Before any services can be performed, the successful bidder must receive written or oral notification in accordance with the practices of the User Department.
7. **PRECEDENCE:** Any requirement set forth in any section of the bid documents shall be binding as if called for by all sections. If there is a difference in the terms anywhere in this document, the most restrictive shall prevail.
8. **ADDITIONS/REVISIONS/DELETIONS:** Additions, revisions or deletions to the general conditions, specifications or bid price sheets that change the intent of the bid will cause the bid to be non-responsive and the bid will not be considered. The Town Administrator shall be the sole judge as to whether any addition, revision or deletion changes the intent of the bid.
9. **TERMINATION/SUSPENSION:** The Town Administrator reserves the right to terminate or suspend the award of this bid, in whole or in part, when it is in the best interest of the Town to do so. The Town Administrator will notify the vendor, in writing, of any such action with notice of the effective date of termination or suspension. This notice shall also specify the state of the work at the time of termination or suspension. If the User Department determines that the performance of the vendor does not comply with the bid requirements, the division may:
 - a. Immediately suspend the work; and
 - b. Notify the vendor of the non-performance with a requirement that the deficiency be corrected within ten (10) days of notification.
10. **PLANS AND SPECIFICATIONS:** The specifications and other bid documents upon which the prices in the vendor's bid proposal are based on, are hereby made a part of the purchase order by reference hereto.
11. **PERFORMANCE AND PAYMENT BOND:** If a bond is required, it will be called out in the Special Conditions section of the bid. The vendor shall furnish a performance and payment bond, in an amount equal to the amount awarded, as security for the faithful performance and payment of all the vendor's obligations under the bid documents. The bond shall remain in effect at least until one year after the date when final payment becomes due, except as provided otherwise by Laws or Regulations or by the bid documents. All bonds shall be in the form prescribed by the bid document except as provided otherwise by Laws or Regulations, and shall be executed by such sureties as are named in the current list of "Companies Holding Certificates of Authority as Acceptable Sureties on Federal Bonds and as Acceptable Reinsuring Companies" as published in Circular 570 (amended) by Audit Staff, Bureau of Government Financial Operations, U.S. Treasury Department and A.M. Best rated A VIII or better.

12. **UNAUTHORIZED ALIEN(S):** The vendor agrees that unauthorized aliens shall not be employed nor utilized in the performance of the requirements of this solicitation. The Town shall consider the employment or utilization of unauthorized aliens a violation of Section 274A(e) of the Immigration and Naturalization Act (8 U.S.C. 1324a). Such violation shall be cause for unilateral termination of this Agreement by the Town.

Employers may avail themselves of a program by the U.S. Immigration and Customs Enforcement called E-Verify. E-Verify is an Internet-based system operated by U.S. Citizenship and Immigration Services (USCIS), part of the Department of Homeland Security (DHS), in partnership with the Social Security Administration (SSA). E-Verify is currently free to employers. E-Verify provides an automated link to Federal databases to help employers determine employment eligibility of new hires and the validity of their Social Security numbers.

If your company wishes to avail themselves of this program, you can register online for E-Verify at <https://www.e-verify.gov/employers>, which provides instructions for completing the registration process. At the end of the registration process, you will be required to sign a Memorandum of Understanding (MOU) that provides the terms of agreement between you as the employer, the SSA, and DHS. An employee who has signatory authority for the employer can sign the MOU. Employers can use their discretion in identifying the best method by which to sign up their locations for E-Verify. To find out more about E-Verify, please visit <https://www.e-verify.gov/employers>.

13. **ANNUAL APPROPRIATIONS:** The vendor acknowledges that the Town, during any fiscal year, shall not expend money, incur any liability, or enter into any agreement which, by its terms, involves the expenditure of money in excess of the amounts budgeted or the reduction of revenues for those budgeted agreements that may be available for expenditure during such fiscal year. Any agreement, verbal or written, made in violation of this subsection is null and void, and no money may be paid on such agreement. Nothing herein contained shall prevent the making of agreements for a period exceeding one year, but any agreement so made shall be executory only for the value of the services to be rendered or agreed to be paid for in succeeding fiscal years. Accordingly, the Town's performance and obligation to pay under this agreement is contingent upon annual appropriation.

14. The Town does not discriminate based on race, color, national origin, sex, religion, age or disability in employment or in the provision of goods and services.

SPECIAL INFORMATION

1. **CONTAMINATION:** Any equipment that is leaking fuel, lubricant, coolant, hydraulic fluid or any other hazardous material shall immediately be repaired by the Contractor to stop the leak. The Contractor shall clean up and dispose of any leaked fluids according to all applicable laws, ordinances, rules and regulations within 24-hours of occurrence. All repairs, removal, clean-up and/or disposal shall be at no cost to the Town.
2. **PERMITS:** The Contractor is responsible for obtaining all permits and licenses. The costs for any permits or licenses shall be the responsibility of the Contractor.
3. **SITE:** The Contractor is responsible for providing a waste dumpster and temporary restroom facility, if applicable.
4. **INSURANCE:** The Contractor is responsible for procuring and maintaining for the duration of the contract insurance against claims for injuries to persons or damages to property which may arise from or in connection with the performance of the work hereunder by the Contractor, his agents, representatives, employees, or subcontractors. A Certificate of Insurance evidencing referenced coverages is to be submitted to the Town of Edisto Beach prior to being awarded any business. See attached Certificate of Insurance request for minimum insurance requirements
5. **SAFETY:** The Contractor is responsible for providing for the safety of all Contractor's or subcontractors personnel working in the Project Area.
6. **WORK AREA CLEAN-UP REQUIREMENTS**
 - a. During the progress of the Work, the Contractor shall keep the premises and maintained travel lanes free from accumulations of waste, discarded or surplus material, rubbish and other debris or contaminants resulting from the Work.
 - b. Following completion of the Work, Contractor shall remove all waste material, rubbish and debris from and about the premises as well as all tools, appliances, construction equipment, machinery and surplus material. The Contractor shall leave the site clean and ready for occupancy by the Town at substantial completion of the Work.
7. **WARRANTY:** Unless otherwise specified, the bidder agrees that the services furnished under this bid shall be covered by the most favorable commercial warranty the bidder gives to any customer for comparable services, and that the rights and remedies provided herein are in addition to and do not limit any rights afforded to the Town by any other provision of this bid. Regardless, all projects are warrantied for one year from date of completion.
8. **INVOICE PAYMENTS**

By signing and submitting an invoice the Contractor certifies that all work and/or materials have been completed in accordance with the Bid Documents.
9. **FINAL INVOICE:** Payment of final invoice will be issued only upon final completion of the work as signed off by the User Department and upon submission of any applicable releases of liens, material documentation, warranties, etc.
10. **HISTORICAL AND ARCHAEOLOGICAL:** If historical or archaeological artifacts are discovered at any time on the project site, the Contractor must notify the Town. The Contractor shall follow any rules or requests from agencies with jurisdiction. If required to stop work, delay work or perform extra work in the affected area, delays and additional costs will be considered an unforeseen difficulty.

11. PERFORMANCE AND PAYMENT BOND: A Performance and a Payment Bond are required for all projects over \$50,000 for 100% of the contract price. The vendor shall furnish a performance and payment bond, in an amount equal to the amount awarded, as security for the faithful performance and payment of all the vendor's obligations under the bid documents. The bond shall remain in effect at least until one year after the date when final payment becomes due, except as provided otherwise by Laws or Regulations or by the bid documents. All bonds shall be in the form prescribed by the bid document except as provided otherwise by Laws or Regulations, and shall be executed by such sureties as are named in the current list of "Companies Holding Certificates of Authority as Acceptable Sureties on Federal Bonds and as Acceptable Reinsuring Companies" as published in Circular 570 (amended) by Audit Staff, Bureau of Government Financial Operations, U.S. Treasury Department and A.M. Best rated A VIII or better.

SCOPE OF WORK

Jungle Shores Bike Path

The Contractor shall repave approximately 4,352 linear feet of a 5-foot-wide asphalt bike path along Jungle Shores Drive to Dawhoo Street and along Dawhoo Street from Jungle Shores to Jungle Road. The Contractor is responsible for verifying all bike path dimensions.

Work Details:

- **Grade Elevation & Drainage:** Raise the finished grade elevation of the existing bike path and slope it toward the road per the attached engineering plans (Exhibit "A") to prevent water, sand, and debris accumulation.
- **Paving & Base Preparation:** Remove existing asphalt, add new base material, grade, compact as necessary, and backfill with approved aggregate in the adjacent roadbed, per Exhibit A.
- **Additional Work:**
 - Install silt fencing and detectable warning materials as specified.
 - Reset or adjust mailboxes as necessary per Exhibit A Notes.

All work and materials shall be completed in accordance with Exhibit A and SCDOT specifications for highway construction (2007 Edition), and book of standard drawings for road construction.

Additional Information:

- o ***ALL PROPOSALS SHALL BE VALID FOR 90 DAYS.***

By signing this proposal, contractor certifies site visit, verifies site conditions and dimensions, and is responsible for the complete work pertaining to site conditions. It is the responsibility of the contractor to verify any quantities provided by the Town.

Direct Questions to Mark Aakhus at maakhus@townofedistobeach.com. Site visits can be arranged.

Site Cleanup

1. Following completion of the work, Contractor shall remove all waste material, rubbish and debris from and about the premises as well as all tools, appliances, construction equipment, machinery and surplus material. The Contractor shall leave the site clean and ready for occupancy by the Town at substantial completion of the work.

BID SHEET BID NO. 2025-03
BID TITLE: Jungle Shores Bike Path Repaving

LUMP SUM BID _____

CONTRACTOR _____
Authorized Representative

ADDRESS _____

TELEPHONE _____

CELL PHONE _____

FAX _____

EMAIL _____

By signing this I, _____, certify I have performed a site visit, verified site conditions and dimensions, and am responsible for the complete work pertaining to site conditions. It is my responsibility to verify any quantities provided by the Town.

Signature

Date

Print Name

TOWN OF EDISTO BEACH CERTIFICATE OF INSURANCE REQUEST

In accordance with your agreement with the Town of Edisto Beach, a Certificate of Insurance evidencing the below referenced coverages is to be submitted to the Town of Edisto Beach prior to any services being performed.

The Certificate of Insurance must evidence the following coverages, and/or terms and conditions (these are minimum requirements) as marked below:

- Provide a Cancellation Clause giving 30 days prior written notice in the event of cancellation, non-renewal or material change in policy.
- Name the Town of Edisto Beach as Additional Insured.
- An Insurance Company Rating Classification of A+, A or A- (Excellent) with financial assets of at least \$100 million.
- General Liability** – Commercial General Liability Limit for bodily injury, personal injury and property damage \$1,000,000 per occurrence; \$2,000,000 aggregate other than products/completed operations. \$2,000,000 aggregate for products/completed operations.
- Workers' Compensation and Employers' Liability** – Workers' Compensation limits as required by the laws of the State of South Carolina and Employers' Liability limits of \$100,000 per accident.
- Automobile Liability** – \$1,000,000 combined single limit per accident for bodily injury and property damage.
- Umbrella Liability** – Combined Single Limit for bodily Injury, Property Damage, Personal & Advertising Injury of \$1,000,000 including Products/Completed Operations and Contractual.
- Certificate Holder should read:
Town of Edisto Beach, 2414 Murray Street, Edisto Beach, SC 29438

Please email Certificate of Insurance to the attention of:

Mark Aakhus

maakhus@townofedistobeach.com

and follow with original via mail to same at:
Town of Edisto Beach, 2414 Murray Street,
Edisto Beach, SC 29438

**PLEASE PROVIDE W-9 and obtain a
business license**

Sample Agreement

This agreement made this ____ day of _____ 2025, by and between the Town of Edisto Beach, South Carolina, herein known as the Owner, and _____, herein known as the Contractor.

WITNESS: That the Contractor and the Owner agree as follow herein:

1. That the Contractor will furnish all labor and materials needed to repave the Jungle Shores Bike Path (RFP No. 2025-03) according to the specifications in the bid package for said project, a copy of which is attached to this agreement as Exhibit A and incorporated fully by reference, and as amended and agreed to by Owner and Contractor. Labor shall be performed in a workmanlike manner in accord with industry standards and customary practices. Upon completion of the work, Contractor shall return the site to clean useable condition to the satisfaction of Owner.
2. The Contractor will allow Owner or other interested parties to inspect all work and materials at all times providing contract oversight to ensure the contractor performs in accordance with the terms, conditions and specification and will, at the Owner's direction, remove all defective materials, whether completed or not. Materials rendered unfit for reworking are to be replaced at Contractor's own expense. All materials and labor, including subcontract work of the contractor must at all times be of quality and standard acceptable to Owner.
3. Indemnity Provision: Contractor assumes entire responsibility and liability for losses, expenses, demands and claims in connection with or arising out of any injury, or alleged injury (including death) to any person, or damage, or alleged damage, to property of the Town of Edisto Beach, any person(s), or third parties sustained or alleged to have been sustained in connection with or to have arisen out of or resulting from the performance of the work/service by the Contractor, his subcontractors, agents, and employees, including losses, expenses or damages sustained by the Town of Edisto Beach, and agrees to indemnify and hold harmless the Town of Edisto Beach, its officials, employees or volunteers from any and all such losses, expenses, damages, demands and claims and agrees to defend any suit or action brought against the Town of Edisto Beach, its officials, employees or volunteers based on any such alleged injury or damage, and to pay all damages, costs and expenses in connection therewith or resulting therefrom, including, but not limited to, reasonable attorney's fees incurred in defense of said suits, actions, or claims. As an integral part of this agreement contractor agrees to purchase and maintain during the life of this contract contractual liability insurance in the amount required in the general liability insurance requirements naming the

Town of Edisto Beach as an additional insured and to furnish proper evidence thereof.

4. Insurance Requirements for Contractors: In accordance with this agreement with the Town of Edisto Beach, a Certificate of Insurance evidencing the below referenced coverages is to be submitted to the Town of Edisto Beach prior to any services being performed. The Certificate of Insurance must evidence the following coverages, and/or terms and conditions (these are minimum requirements) as marked below:

- Provide a Cancellation Clause giving 30 days prior written notice in the event of cancellation, non-renewal or material change in policy.
- Name the **Town of Edisto Beach** as Additional Insured.
- An Insurance Company Rating Classification of A+, A or A- (Excellent) with financial assets of at least \$100 million.
- **General Liability** - Commercial General Liability Limit for bodily injury, personal injury, and property damage \$1,000,000 per occurrence; \$2,000,000 aggregate other than products/completed operations. \$2,000,000 aggregate for products/completed operations.
- **Workers' Compensation and Employers' Liability**-Workers' Compensation limits as required by the laws of the State of South Carolina and Employer's Liability limits of \$100,000 per accident.
- **Automobile Liability**- \$1,000,000 combined single limit per accident for bodily injury and property damage.
- **Umbrella Liability-Combined Single Limit for bodily injury, Property Damage, Personal & Advertising Injury** of \$1,000,000 including Products/Completed Operations and Contractual.
- **PERFORMANCE AND PAYMENT BOND:** In the amount equal to the contract price.

Certificate Holder should read:

Town of Edisto Beach, 2414 Murray Street, Edisto Beach, SC 29438

Please email Certificate of Insurance to the attention of:

Mark Aakhus, Town Administrator

maakhus@townofedistobeach.com

and follow with original via mail to same at:

Town of Edisto Beach, 2414 Murray Street,
Edisto Beach, SC 29438

5. Contractor shall obtain all required permits and licenses.
6. The contract price is _____ to repair and repave the Jungle Shores Bike Path. Changes in contract price require Town Council approval. If a change is requested, it must be submitted in writing as a change order. Change Orders and subsequent contract prices can only be authorized by Town Council. Any work performed without Town Council approval does not obligate Owner.

7. The Contractor will complete all work included in this agreement within 60 days, unless delayed by conditions beyond his control, in which case time will be extended the actual number of days so delayed, but only if approved in writing.
8. Any work performed without Town Council approval and written notice to proceed does not obligate Owner.
9. Final payment will not be due until Contractor has delivered to Owner complete releases for all claims arising from this contract, or receipts in full covering all labor and materials for which liens could be filed, or bond be furnished Owner against any such lien.
10. The Contractor hereby warrants and guarantees to the satisfaction of the Owner all materials and workmanship constructed for a period of one (1) year from the date of final completion or commercial warranty (whichever is greater) of this contract.
11. The parties agree that the non-prevailing party shall reimburse the prevailing party for actual costs and reasonable attorney's fees incurred by the prevailing party in enforcing its rights against the non-prevailing party under this agreement.
12. This Agreement will be binding on the parties hereto, their assigns, successors, representatives or administrators.
13. Nothing herein shall be construed or interpreted to imply that the Contractor, its employees, agents, and/or subcontractors shall be the employees of the Owner. The Contractor, its employees, agents, and subcontractors are independent contractors.
14. Any and all representations by either of the parties or their agents made during negotiations prior to the execution of this agreement and which representations are not contained in the provisions hereof shall not be binding upon either of the parties hereto. This agreement constitutes the full and complete agreement of the parties and shall not be modified, amended, or changed in any manner except upon express written consent of the parties to this agreement.
15. Should any part of this agreement be found to be unenforceable by any court or other competent authority, then the rest shall remain in full force and effect.
16. This agreement shall be governed, construed and interpreted by, through and under the Laws of the State of South Carolina. The parties agree that venue for any dispute arising from this contract or the performance of the terms thereof shall be in the Court of Common Pleas for Colleton County, South Carolina, and further, the parties subject themselves to the personal and subject matter jurisdiction of said court regardless of the amount in controversy.

Contractor certifies that:

- A. This Bid is genuine and not made in the interest of or on behalf of any undisclosed individual or entity and is not submitted in conformity with any collusive agreement or rules of any group, association, organization, or corporation;
- B. Contractor has not directly or indirectly induced or solicited any other Bidder to submit a false or sham Bid;
- C. Contractor has not solicited or induced any individual or entity to refrain from bidding; and
- D. Contractor has not engaged in corrupt, fraudulent, collusive, or coercive practices in competing for the Contract. For the purposes of this Paragraph 4.01.D:
 - 1. "corrupt practice" means the offering, giving, receiving, or soliciting of anything of value likely to influence the action of a public official in the bidding process;
 - 2. "fraudulent practice" means an intentional misrepresentation of facts made (a) to influence the bidding process to the detriment of Owner, (b) to establish bid prices at artificial non-competitive levels, or (c) to deprive Owner of the benefits of free and open competition;
 - 3. "collusive practice" means a scheme or arrangement between two or more Bidders, with or without the knowledge of Owner, a purpose of which is to establish bid prices at artificial, non-competitive levels; and
 - 4. "coercive practice" means harming or threatening to harm, directly or indirectly, persons or their property to influence their participation in the bidding process or affect the execution of the Contract.
- E. Contractor has not been debarred.

17. Neither party to this agreement may assign its rights or obligations herein without the prior written consent of the other party.

18. Termination Clauses:

Termination for Convenience

Owner may at any time and for any reason terminate Contractor's services and work at Owner's convenience. Upon receipt of such notice, Contractor shall, unless the notice directs otherwise, immediately discontinue the work and placing of orders for materials, facilities and supplies in connection with the performance of this Agreement.

Upon such termination, Contractor shall be entitled to payment only as follows: (1) the actual cost of the work completed in conformity with this Agreement; plus, (2) such other costs actually incurred by Contractor as are permitted by the contract and approved by Owner; (3) plus ten percent (10%) of the cost of the work referred to in subparagraph (1) above for overhead and profit. There shall be deducted from such sums as provided in this subparagraph the amount of any payments made to Contractor prior to the date of the termination of this Agreement. Contractor shall not be entitled to any claim or claim of lien against Owner for any additional compensation or damages in the event of such termination and payment.

Termination for Cause by Either Party

If one party should breach or fail to perform any provision of this Agreement, then the other party may give written notice of such default (Notice of Default) to the breaching party. If the breaching party should fail to cure such default within ten (10) days of notice thereof, the non-breaching party shall have the right to terminate this Agreement by a second written notice (Notice of Termination) to the breaching party. If a Notice of Termination is sent to the breaching party, this Agreement shall automatically terminate on the effective date of such notice. Termination shall not relieve the breaching party of its obligation to pay all amounts due to the non-breaching party as of the effective date of termination and shall not impair any accrued rights, including the right to pursue all available legal remedies for damages, of the non-breaching party.

Owner, Town of Edisto Beach

Contractor

Date

Date

Witness

Witness

| STATE | COUNTY | ROUTE NAME | D&F PROJECT NO | ROUTE NO. | SHEET NO. | TOTAL SHEETS |
|-------|----------|--------------------------------|----------------|-----------|-----------|--------------|
| S.C. | COLLETON | JUNGLE SHORES DR AND DAWHOO ST | 31893.05 | | 1 | 9 |

APPENDIX A

TOWN OF EDISTO BEACH

JUNGLE SHORES DRIVE AND DAWHOO STREET PATH IMPROVEMENTS

| INDEX OF SHEETS | | |
|-----------------|-----------------------|--------------|
| SHEET # | DESCRIPTION | SHEET TOTALS |
| 1 | TITLE SHEET | 1 |
| 3 | TYPICAL SECTIONS | 1 |
| 5A-5B | REFERENCE DATA SHEETS | 2 |
| 6-10 | PLAN SHEETS | 5 |
| TOTAL SHEETS | | 9 |

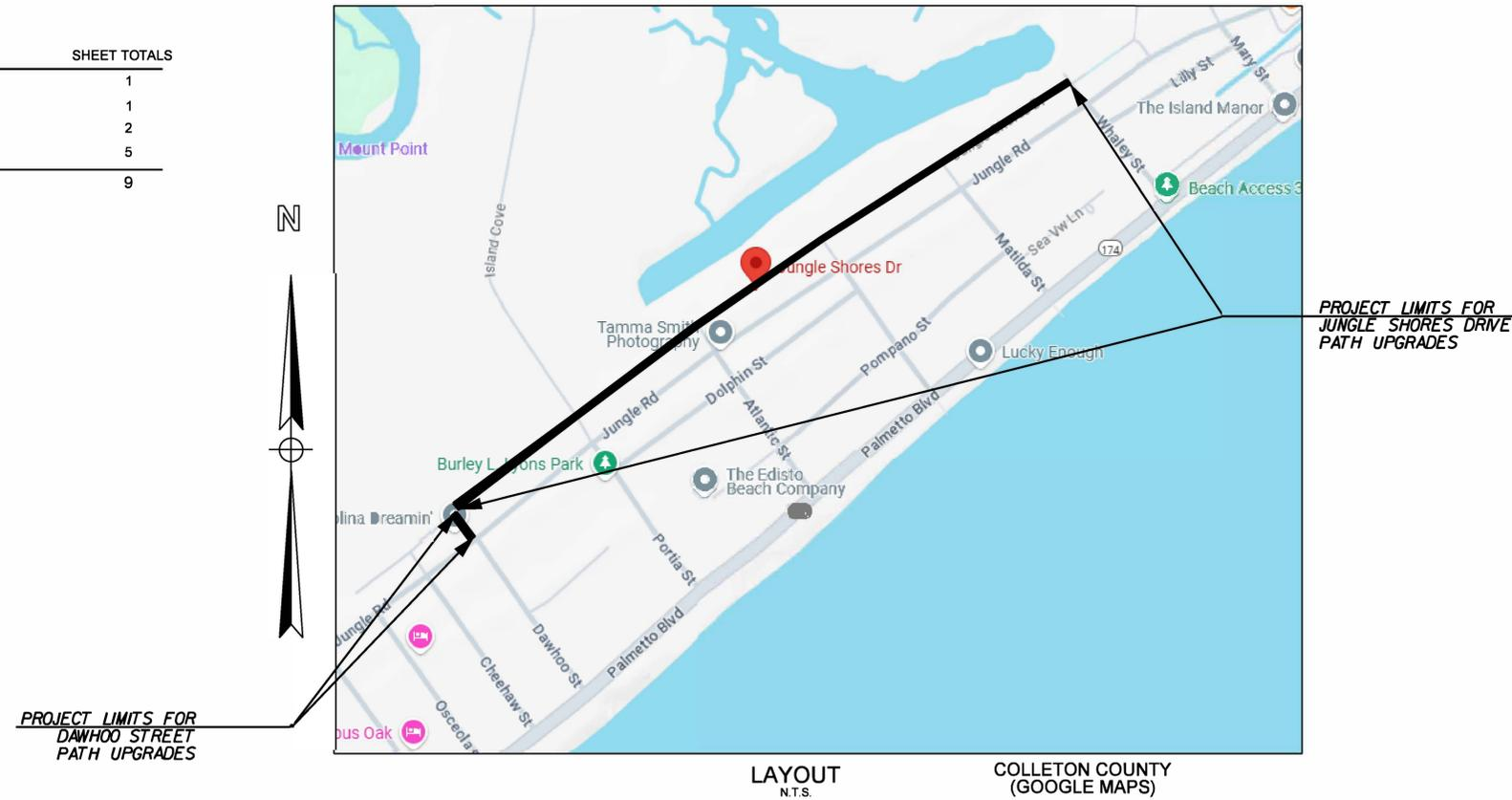

LAYOUT
N.T.S. COLLETON COUNTY
(GOOGLE MAPS)

NOTE: ALL WORKMANSHIP AND MATERIAL ON THIS PROJECT TO CONFORM WITH SOUTH CAROLINA DEPARTMENT OF TRANSPORTATION STANDARD SPECIFICATIONS FOR HIGHWAY CONSTRUCTION (2007 EDITION), AND BOOK OF STANDARD DRAWINGS FOR ROAD CONSTRUCTION.



3 DAYS BEFORE DIGGING IN
SOUTH CAROLINA
CALL 811
PALMETTO UTILITY PROTECTION SERVICES, INC. (PUPS)
ALL UTILITIES MAY NOT BE A MEMBER OF PUPS.

SCALE: 2640.0000 ft. / in.
PEN TABLE: JUNGLE SHORES_PLANS.tbl
PLOT DRIVER: PDF.plt
FILE: /2025
G:\Jobs\001\31893-05\Production\Transportation\SHEETS\001_31893-05_TITLE SHEET.DGN

| FED. ROAD DIV. NO. | STATE | COUNTY | ROAD NAME | ROUTE NO. | SHEET NO. | TOTAL SHEETS |
|--------------------|-------|----------|----------------------------------|-----------|-----------|--------------|
| 3 | S.C. | COLLETON | JUNGLE SHORES DR. AND DAWHOO ST. | | 3 | |

TYPICAL SECTION
JUNGLE SHORES DRIVE &
DAWHOO STREET PATH
TOWN OF EDISTO BEACH

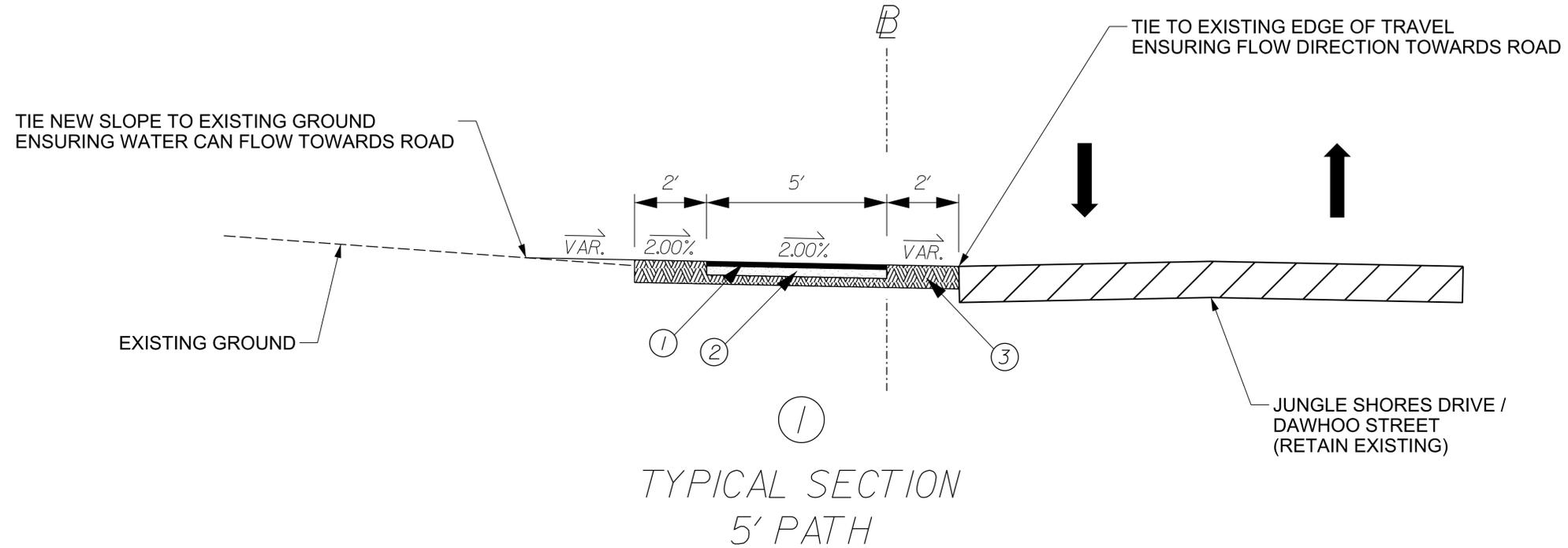

PAVEMENT LEGEND

| | |
|---|---|
| ① | 1.5" H/M ASPHALT CONCRETE SURFACE COURSE |
| ② | 3" COMPACTED CRUSHER RUN STONE (95% COMPACTED BY STANDARD PROCTOR) |
| ③ | COMPACTED SUBGRADE |

SCALE: 2.0000 ft. / in.
 PEN TABLE: JUNGLE SHORES_PLANS.tbl
 PLOT DRIVER: PDF.plt
 FILE: G:\Jobs\001\31893-05\Production\Transportation\SHEETS\003_31893-05_TYPICAL SHEETS.DGN
 3/24/2025

FOR
INFORMATION
ONLY

DAVIS & FLOYD

SINCE 1954

1940 ALGONQUIN ROAD,
SUITE 301
CHARLESTON, SC 29405
(843) 554-8602

| 5 | | | | | | | |
|-------------|----------|------------|-------------------------|--|--|--|--|
| 4 | | | | | | | |
| 3 | | | | | | | |
| 2 | | | | | | | |
| 1 | | | | | | | |
| REV. NO. | BY | DATE | DESCRIPTION OF REVISION | | | | |
| DESIGNED BY | DRAWN BY | CHECKED BY | N.T.S. | | | | |

TOWN OF EDISTO BEACH

JUNGLE SHORES DR. AND
DAWHOO ST. PATH UPGRADES
TYPICAL SECTION

PLOT SIZE = 22" x 34"

| FED. ROAD DIV. NO. | STATE | COUNTY | ROAD NAME | ROUTE NO. | SHEET NO. | TOTAL SHEETS |
|--------------------|-------|----------|----------------------------------|-----------|-----------|--------------|
| 3 | S.C. | COLLETON | JUNGLE SHORES DR. AND DAWHOO ST. | | 5A | |

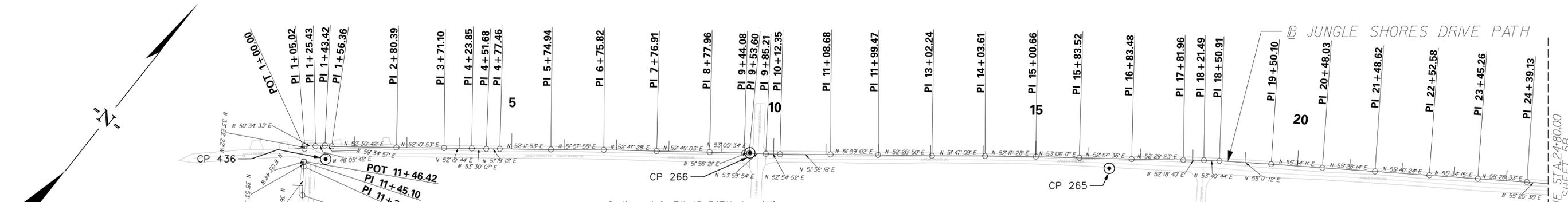

DAWHOO STREET PATH

Beginning chain EX DAWHOO SW description

| | | | | | | |
|--|---|--------------|---|----------------|-----|----------|
| Point 65 | N | 240,867.9230 | E | 2,210,785.3330 | Sta | 10+00.00 |
| Course from 65 to 66 N 15° 36' 22.84" W Dist 6.6388 | | | | | | |
| Point 66 | N | 240,874.3170 | E | 2,210,783.5470 | Sta | 10+06.64 |
| Course from 66 to 67 N 33° 55' 46.03" W Dist 74.9465 | | | | | | |
| Point 67 | N | 240,936.5020 | E | 2,210,741.7140 | Sta | 10+81.59 |
| Course from 67 to 68 N 36° 11' 47.38" W Dist 54.8974 | | | | | | |
| Point 68 | N | 240,980.8040 | E | 2,210,709.2940 | Sta | 11+36.48 |
| Course from 68 to 69 N 35° 53' 38.19" W Dist 8.6187 | | | | | | |
| Point 69 | N | 240,987.7860 | E | 2,210,704.2410 | Sta | 11+45.10 |
| Course from 69 to 70 N 6° 05' 43.59" W Dist 1.3185 | | | | | | |
| Point 70 | N | 240,989.0970 | E | 2,210,704.0100 | Sta | 11+46.42 |

Ending chain EX DAWHOO SW description

Beginning chain EX JS PATH description

| | | | | | | |
|---|---|--------------|---|----------------|-----|---------|
| Point 1 | N | 241,008.2643 | E | 2,210,689.9107 | Sta | 1+00.00 |
| Course from 1 to 2 N 33° 22' 21.90" W Dist 5.0206 | | | | | | |
| Point 2 | N | 241,012.4570 | E | 2,210,687.1490 | Sta | 1+05.02 |
| Course from 2 to 3 N 50° 34' 32.57" E Dist 20.4139 | | | | | | |
| Point 3 | N | 241,025.4210 | E | 2,210,702.9180 | Sta | 1+25.43 |
| Course from 3 to 4 N 48° 05' 41.89" E Dist 17.9818 | | | | | | |
| Point 4 | N | 241,037.4310 | E | 2,210,716.3010 | Sta | 1+43.42 |
| Course from 4 to 5 N 59° 34' 57.47" E Dist 12.9465 | | | | | | |
| Point 5 | N | 241,043.9858 | E | 2,210,727.4656 | Sta | 1+56.36 |
| Course from 5 to 6 N 52° 30' 42.08" E Dist 124.0282 | | | | | | |
| Point 6 | N | 241,119.4693 | E | 2,210,825.8792 | Sta | 2+80.39 |
| Course from 6 to 7 N 52° 10' 52.55" E Dist 90.7075 | | | | | | |
| Point 7 | N | 241,175.0880 | E | 2,210,897.5340 | Sta | 3+71.10 |
| Course from 7 to 8 N 52° 19' 44.27" E Dist 52.7534 | | | | | | |
| Point 8 | N | 241,207.3270 | E | 2,210,939.2900 | Sta | 4+23.85 |
| Course from 8 to 9 N 53° 30' 06.85" E Dist 27.8314 | | | | | | |
| Point 9 | N | 241,223.8810 | E | 2,210,961.6630 | Sta | 4+51.68 |
| Course from 9 to 10 N 51° 19' 12.21" E Dist 25.7773 | | | | | | |
| Point 10 | N | 241,239.9910 | E | 2,210,981.7860 | Sta | 4+77.46 |

Continue chain EX JS PATH description

| | | | | | | |
|---|---|--------------|---|----------------|-----|----------|
| Course from 10 to 11 N 52° 11' 53.04" E Dist 97.4771 | | | | | | |
| Point 11 | N | 241,299.7380 | E | 2,211,058.8060 | Sta | 5+74.94 |
| Course from 11 to 12 N 51° 57' 54.96" E Dist 100.8814 | | | | | | |
| Point 12 | N | 241,361.8950 | E | 2,211,138.2640 | Sta | 6+75.82 |
| Course from 12 to 13 N 52° 47' 27.78" E Dist 101.0892 | | | | | | |
| Point 13 | N | 241,423.0260 | E | 2,211,218.7750 | Sta | 7+76.91 |
| Course from 13 to 14 N 52° 45' 03.25" E Dist 101.0538 | | | | | | |
| Point 14 | N | 241,484.1920 | E | 2,211,299.2150 | Sta | 8+77.96 |
| Course from 14 to 15 N 53° 05' 33.61" E Dist 66.1224 | | | | | | |
| Point 15 | N | 241,523.9000 | E | 2,211,352.0870 | Sta | 9+44.08 |
| Course from 15 to 16 N 51° 56' 20.93" E Dist 9.5167 | | | | | | |
| Point 16 | N | 241,529.7670 | E | 2,211,359.5800 | Sta | 9+53.60 |
| Course from 16 to 17 N 53° 59' 54.05" E Dist 31.6106 | | | | | | |
| Point 17 | N | 241,548.3480 | E | 2,211,385.1530 | Sta | 9+85.21 |
| Point 18 | N | 241,548.3480 | E | 2,211,385.1530 | Sta | 9+85.21 |
| Course from 18 to 19 N 52° 54' 51.52" E Dist 27.1356 | | | | | | |
| Point 19 | N | 241,564.7110 | E | 2,211,406.8000 | Sta | 10+12.35 |
| Course from 19 to 20 N 51° 56' 16.25" E Dist 96.3317 | | | | | | |
| Point 20 | N | 241,624.1010 | E | 2,211,482.6460 | Sta | 11+08.68 |
| Course from 20 to 21 N 51° 59' 01.73" E Dist 90.7866 | | | | | | |
| Point 21 | N | 241,680.0150 | E | 2,211,554.7100 | Sta | 11+99.47 |
| Course from 21 to 22 N 52° 26' 50.21" E Dist 102.7759 | | | | | | |
| Point 22 | N | 241,742.6560 | E | 2,211,635.6510 | Sta | 13+02.24 |
| Course from 22 to 23 N 51° 47' 08.50" E Dist 101.3717 | | | | | | |
| Point 23 | N | 241,805.3650 | E | 2,211,715.2990 | Sta | 14+03.61 |
| Course from 23 to 24 N 52° 17' 28.06" E Dist 97.0474 | | | | | | |
| Point 24 | N | 241,864.7240 | E | 2,211,792.0760 | Sta | 15+00.66 |
| Course from 24 to 25 N 53° 06' 17.26" E Dist 82.8562 | | | | | | |
| Point 25 | N | 241,914.4670 | E | 2,211,858.3390 | Sta | 15+83.52 |
| Course from 25 to 26 N 52° 57' 35.54" E Dist 99.9644 | | | | | | |
| Point 26 | N | 241,974.6830 | E | 2,211,938.1320 | Sta | 16+83.48 |
| Course from 26 to 27 N 52° 29' 23.14" E Dist 98.4804 | | | | | | |
| Point 27 | N | 242,034.6480 | E | 2,212,016.2510 | Sta | 17+81.96 |
| Course from 27 to 28 N 52° 18' 40.07" E Dist 39.5290 | | | | | | |
| Point 28 | N | 242,058.8150 | E | 2,212,047.5320 | Sta | 18+21.49 |
| Course from 28 to 29 N 53° 40' 43.86" E Dist 29.4237 | | | | | | |
| Point 29 | N | 242,076.2430 | E | 2,212,071.2390 | Sta | 18+50.91 |
| Course from 29 to 30 N 55° 17' 11.82" E Dist 99.1884 | | | | | | |
| Point 30 | N | 242,132.7280 | E | 2,212,152.7730 | Sta | 19+50.10 |
| Course from 30 to 31 N 55° 34' 10.61" E Dist 97.9263 | | | | | | |
| Point 31 | N | 242,188.0960 | E | 2,212,233.5440 | Sta | 20+48.03 |
| Course from 31 to 32 N 55° 28' 13.60" E Dist 100.5943 | | | | | | |
| Point 32 | N | 242,245.1160 | E | 2,212,316.4170 | Sta | 21+48.62 |

Continue chain EX JS PATH description

| | | | | | | |
|---|---|--------------|---|----------------|-----|----------|
| Course from 32 to 33 N 55° 40' 23.81" E Dist 103.9614 | | | | | | |
| Point 33 | N | 242,303.7410 | E | 2,212,402.2720 | Sta | 22+52.58 |
| Course from 33 to 34 N 55° 34' 15.30" E Dist 92.6801 | | | | | | |
| Point 34 | N | 242,356.1410 | E | 2,212,478.7170 | Sta | 23+45.26 |
| Course from 34 to 35 N 55° 28' 33.29" E Dist 93.8611 | | | | | | |
| Point 35 | N | 242,409.3370 | E | 2,212,556.0480 | Sta | 24+39.13 |

CONTROL POINTS

| ID | DESCRIPTION | NORTHING | EASTING | STATION | OFFSET | ELEVATION |
|--------|-------------|------------|-------------|----------|--------|-----------|
| CP 436 | NLS | 241018.039 | 2210733.593 | 1+48.51 | 25.48 | 5.51 |
| CP 266 | PKS | 241530.895 | 2211360.078 | 9+54.67 | -0.62 | 6.05 |
| CP 265 | NLS | 241934.256 | 2211915.546 | 16+41.10 | 18.66 | 6.40 |

PROJECT DATUM DESCRIPTION:
HORIZONTAL DATUM: NAD83
VERTICAL DATUM: NAVD'88

SCALE: 100,0000 ft / in.
PEN TABLE: JUNGLE SHORES_PLANS.tbl
FILE: G:\Jobs\001\31893-05\Production\Transportation\Sheets\005_31893-05_REF DATA SHEETS.DGN
3/24/2025



FOR INFORMATION ONLY

DAVIS & FLOYD
SINCE 1954

1940 ALGONQUIN ROAD,
SUITE 301
CHARLESTON, SC 29405
(843) 554-8602

| 5 | | | |
|-------------|----|----------|-------------------------|
| 4 | | | |
| 3 | | | |
| 2 | | | |
| 1 | | | |
| REV. NO. | BY | DATE | DESCRIPTION OF REVISION |
| DESIGNED BY | | DRAWN BY | CHECKED BY |

TOWN OF EDISTO BEACH

JUNGLE SHORES DR. AND DAWHOO ST. PATH UPGRADES PLAN SHEETS

SCALE 1" = 100'
PLOT SIZE = 22" x 34"

MATCHLINE STA 24+80.00 SEE SHEET 5B

| FED. ROAD DIV. NO. | STATE | COUNTY | ROAD NAME | ROUTE NO. | SHEET NO. | TOTAL SHEETS |
|--------------------|-------|----------|----------------------------------|-----------|-----------|--------------|
| 3 | S.C. | COLLETON | JUNGLE SHORES DR. AND DAWHOO ST. | | 5B | |

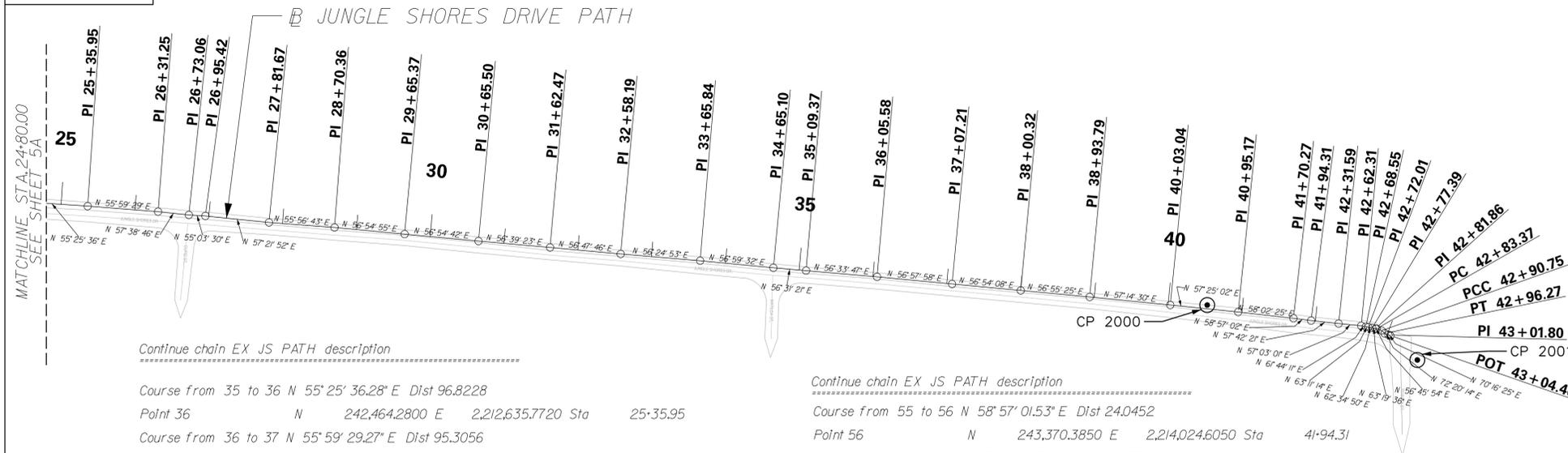

Continue chain EX JS PATH description

| | | | | | | |
|----------------------|---|--------------|---|----------------|-----|----------|
| Course from 35 to 36 | N | 242,464,2800 | E | 2,212,635,7720 | Sta | 25-35.95 |
| Course from 36 to 37 | N | 242,517,5860 | E | 2,212,714,7760 | Sta | 26-31.25 |
| Course from 37 to 38 | N | 242,517,5860 | E | 2,212,714,7760 | Sta | 26-31.25 |
| Course from 38 to 39 | N | 242,539,9570 | E | 2,212,750,0900 | Sta | 26-73.06 |
| Course from 39 to 40 | N | 242,552,7640 | E | 2,212,768,4200 | Sta | 26-95.42 |
| Course from 40 to 41 | N | 242,599,2790 | E | 2,212,841,0540 | Sta | 27-81.67 |
| Course from 41 to 42 | N | 242,648,9420 | E | 2,212,914,5310 | Sta | 28-70.36 |
| Course from 42 to 43 | N | 242,700,8070 | E | 2,212,994,1380 | Sta | 29-65.37 |
| Course from 43 to 44 | N | 242,755,4740 | E | 2,213,078,0340 | Sta | 30-65.50 |
| Course from 44 to 45 | N | 242,808,7740 | E | 2,213,159,0410 | Sta | 31-62.47 |
| Course from 45 to 46 | N | 242,861,1880 | E | 2,213,239,1260 | Sta | 32-58.19 |
| Course from 46 to 47 | N | 242,920,7400 | E | 2,213,328,8090 | Sta | 33-65.84 |
| Course from 47 to 48 | N | 242,974,8130 | E | 2,213,412,0490 | Sta | 34-65.10 |
| Course from 48 to 49 | N | 242,999,2350 | E | 2,213,448,9780 | Sta | 35-09.37 |
| Course from 49 to 50 | N | 243,052,2440 | E | 2,213,529,2580 | Sta | 36-05.58 |
| Course from 50 to 51 | N | 243,107,6480 | E | 2,213,614,4620 | Sta | 37-07.21 |
| Course from 51 to 52 | N | 243,158,4910 | E | 2,213,692,4620 | Sta | 38-00.32 |
| Course from 52 to 53 | N | 243,209,5030 | E | 2,213,770,7850 | Sta | 38-93.79 |
| Course from 53 to 54 | N | 243,268,6190 | E | 2,213,862,6620 | Sta | 40-03.04 |
| Course from 54 to 55 | N | 243,318,2340 | E | 2,213,940,2940 | Sta | 40-95.17 |
| Course from 55 to 56 | N | 243,357,9830 | E | 2,214,004,0050 | Sta | 41-70.27 |

Continue chain EX JS PATH description

| | | | | | | |
|----------------------|---|--------------|---|----------------|-----|----------|
| Course from 55 to 56 | N | 243,370,3850 | E | 2,214,024,6050 | Sta | 41-94.31 |
| Course from 56 to 57 | N | 243,390,3010 | E | 2,214,056,1160 | Sta | 42-31.59 |
| Course from 57 to 58 | N | 243,407,0080 | E | 2,214,081,8920 | Sta | 42-62.31 |
| Course from 58 to 59 | N | 243,409,9643 | E | 2,214,087,3909 | Sta | 42-68.55 |
| Course from 59 to 60 | N | 243,411,5560 | E | 2,214,090,4590 | Sta | 42-72.01 |
| Course from 60 to 61 | N | 243,413,9867 | E | 2,214,095,2684 | Sta | 42-77.39 |
| Course from 61 to 62 | N | 243,415,9930 | E | 2,214,099,2620 | Sta | 42-81.86 |
| Course from 62 to PC | N | 243,415,9930 | E | 2,214,099,2620 | Sta | 42-81.86 |

Curve Data

| | | | | | | |
|-------------------|----------|---------------------|--------------|----------------|----------------|--|
| Curve EX_JS_PATH1 | | | | | | |
| P.I. Station | 42-87.12 | N | 243,418,7269 | E | 2,214,103,7524 | |
| Delta | = | 26° 06' 47.37" (RT) | | | | |
| Degree | = | 353° 51' 29.78" | | | | |
| Tangent | = | 3.7550 | | | | |
| Length | = | 7.3796 | | | | |
| Radius | = | 16.1917 | | | | |
| External | = | 0.4297 | | | | |
| Long Chord | = | 7.3158 | | | | |
| Mid. Ord. | = | 0.4186 | | | | |
| P.C. Station | 42-83.37 | N | 243,416,8169 | E | 2,214,100,5194 | |
| P.T. Station | 42-90.75 | N | 243,419,0190 | E | 2,214,107,4960 | |
| C.C. | = | 243,402,8763 | E | 2,214,108,7554 | | |
| Back | = | N 59° 25' 32.85" E | | | | |
| Ahead | = | N 85° 32' 20.22" E | | | | |
| Chord Bear | = | N 72° 28' 56.53" E | | | | |

Curve Data

| | | | | | | |
|-------------------|----------|---------------------|--------------|----------------|----------------|--|
| Curve EX_JS_PATH2 | | | | | | |
| P.I. Station | 42-93.53 | N | 243,419,2358 | E | 2,214,110,2747 | |
| Delta | = | 19° 32' 01.70" (RT) | | | | |
| Degree | = | 353° 51' 29.74" | | | | |
| Tangent | = | 2.7872 | | | | |
| Length | = | 5.5202 | | | | |
| Radius | = | 16.1917 | | | | |
| External | = | 0.2381 | | | | |
| Long Chord | = | 5.4935 | | | | |
| Mid. Ord. | = | 0.2347 | | | | |
| P.C. Station | 42-90.75 | N | 243,419,0190 | E | 2,214,107,4960 | |
| P.T. Station | 42-96.27 | N | 243,418,5110 | E | 2,214,112,9660 | |
| C.C. | = | 243,402,8763 | E | 2,214,108,7554 | | |
| Back | = | N 85° 32' 20.22" E | | | | |
| Ahead | = | S 74° 55' 38.09" E | | | | |
| Chord Bear | = | S 84° 41' 38.93" E | | | | |

| | | | | | | |
|----------------------------------|---|--------------|---|----------------|-----|----------|
| Course from PT EX_JS_PATH2 to 63 | N | 243,420,1910 | E | 2,214,118,2420 | Sta | 43-01.80 |
| Course from 63 to 64 | N | 243,421,0860 | E | 2,214,120,7380 | Sta | 43-04.46 |

Ending chain EX_JS_PATH description

| CONTROL POINTS | | | | | | |
|----------------|-------------|------------|-------------|-----------|--------|-----------|
| ID | DESCRIPTION | NORTHING | EASTING | STATION | OFFSET | ELEVATION |
| CP 2000 | NLS | 243299.552 | 2213901.743 | 40+52.63 | -5.02 | 4.59 |
| CP 2001 | NLS | 243417.971 | 2214169.820 | OFF CHAIN | 19.50 | 4.51 |

PROJECT DATUM DESCRIPTION:
HORIZONTAL DATUM: NAD83
VERTICAL DATUM: NAVD'88

SCALE: 100,0000 ft. / in.
 PEN TABLE: JUNGLE SHORES_PLANS.tbl
 PLOT DRIVER: PDF.plt
 FILE: G:\Jobs\004\31893-05\Production\Transportation\SHEETS\005_31893-05_REF DATA SHEETS.DGN
 3/24/2025



FOR INFORMATION ONLY

DAVIS & FLOYD
SINCE 1954

1940 ALGONQUIN ROAD,
SUITE 301
CHARLESTON, SC 29405
(843) 554-8602

| 5 | | | | |
|-------------|----|------|-------------------------|------------|
| 4 | | | | |
| 3 | | | | |
| 2 | | | | |
| 1 | | | | |
| REV. NO. | BY | DATE | DESCRIPTION OF REVISION | |
| DESIGNED BY | | | DRAWN BY | CHECKED BY |

| | |
|--|-----------------------|
| TOWN OF EDISTO BEACH | |
| JUNGLE SHORES DR. AND DAWHOO ST. PATH UPGRADES PLAN SHEETS | |
| SCALE 1" = 100' | PLOT SIZE = 22" x 34" |

| FED. ROAD DIV. NO. | STATE | COUNTY | ROAD NAME | ROUTE NO. | SHEET NO. | TOTAL SHEETS |
|--------------------|-------|----------|----------------------------------|-----------|-----------|--------------|
| 3 | S.C. | COLLETON | JUNGLE SHORES DR. AND DAWHOO ST. | | 6 | |

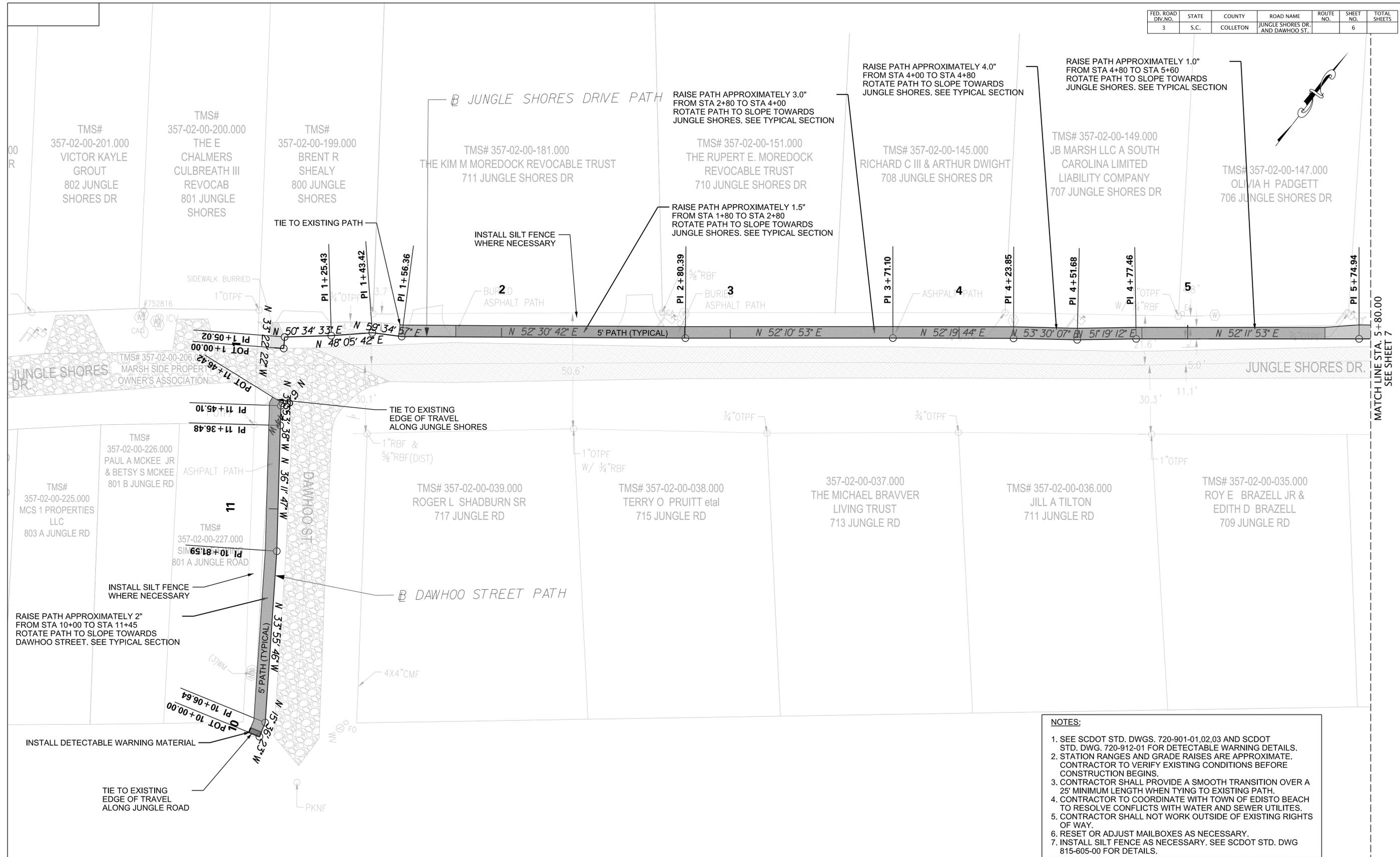

- NOTES:**
- SEE SCDOT STD. DWGS. 720-901-01, 02, 03 AND SCDOT STD. DWG. 720-912-01 FOR DETECTABLE WARNING DETAILS.
 - STATION RANGES AND GRADE RAISES ARE APPROXIMATE. CONTRACTOR TO VERIFY EXISTING CONDITIONS BEFORE CONSTRUCTION BEGINS.
 - CONTRACTOR SHALL PROVIDE A SMOOTH TRANSITION OVER A 25' MINIMUM LENGTH WHEN TYING TO EXISTING PATH.
 - CONTRACTOR TO COORDINATE WITH TOWN OF EDISTO BEACH TO RESOLVE CONFLICTS WITH WATER AND SEWER UTILITIES.
 - CONTRACTOR SHALL NOT WORK OUTSIDE OF EXISTING RIGHTS OF WAY.
 - RESET OR ADJUST MAILBOXES AS NECESSARY.
 - INSTALL SILT FENCE AS NECESSARY. SEE SCDOT STD. DWG 815-605-00 FOR DETAILS.

SCALE: 20,000 ft. / in.
 PEN TABLE: JUNGLE SHORES_PLANS.tbl
 PLOT DRIVER: PDF.plt
 FILE: G:\Jobs\05\1893-05\Production\Transportation\Sheets\006_31893-05_PLAN SHEETS.DGN
 3/24/2025



FOR INFORMATION ONLY

DAVIS & FLOYD
 SINCE 1954

1940 ALGONQUIN ROAD,
 SUITE 301
 CHARLESTON, SC 29405
 (843) 554-8602

| 5 | | | |
|-------------|----|----------|-------------------------|
| 4 | | | |
| 3 | | | |
| 2 | | | |
| 1 | | | |
| REV. NO. | BY | DATE | DESCRIPTION OF REVISION |
| DESIGNED BY | | DRAWN BY | CHECKED BY |

TOWN OF EDISTO BEACH

JUNGLE SHORES DR. AND DAWHOO ST. PATH UPGRADES PLAN SHEETS

SCALE 1" = 20'
 PLOT SIZE = 22" x 34"

MATCH LINE STA. 5+80.00
 SEE SHEET 7

| FED. ROAD DIV. NO. | STATE | COUNTY | ROAD NAME | ROUTE NO. | SHEET NO. | TOTAL SHEETS |
|--------------------|-------|----------|----------------------------------|-----------|-----------|--------------|
| 3 | S.C. | COLLETON | JUNGLE SHORES DR. AND DAWHOO ST. | | 7 | |

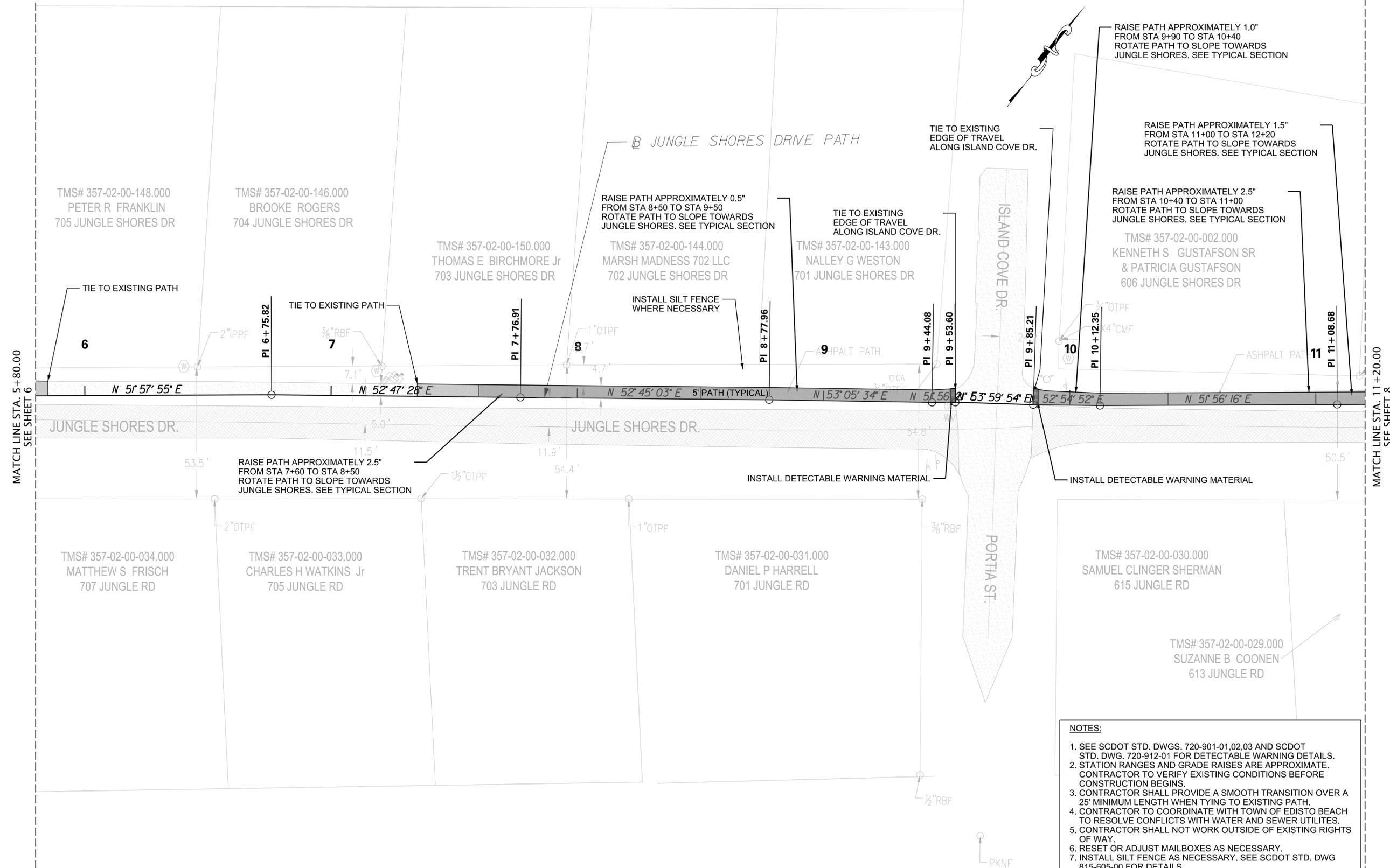

- NOTES:**
- SEE SCDOT STD. DWGS. 720-901-01,02,03 AND SCDOT STD. DWG. 720-912-01 FOR DETECTABLE WARNING DETAILS.
 - STATION RANGES AND GRADE RAISES ARE APPROXIMATE. CONTRACTOR TO VERIFY EXISTING CONDITIONS BEFORE CONSTRUCTION BEGINS.
 - CONTRACTOR SHALL PROVIDE A SMOOTH TRANSITION OVER A 25' MINIMUM LENGTH WHEN TYING TO EXISTING PATH.
 - CONTRACTOR TO COORDINATE WITH TOWN OF EDISTO BEACH TO RESOLVE CONFLICTS WITH WATER AND SEWER UTILITIES.
 - CONTRACTOR SHALL NOT WORK OUTSIDE OF EXISTING RIGHTS OF WAY.
 - RESET OR ADJUST MAILBOXES AS NECESSARY.
 - INSTALL SILT FENCE AS NECESSARY. SEE SCDOT STD. DWG 815-605-00 FOR DETAILS.

SCALE: 20,000.00 ft / in.
 PEN TABLE: JUNGLE SHORES_PLANS.tbl
 PLOT DRIVER: PDF.plt
 FILE: G:\Jobs\05\31893-05\Production\Transportation\Sheets\006_31893-05_PLAN SHEETS.DGN
 3/24/2025

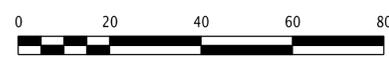

FOR INFORMATION ONLY

DAVIS & FLOYD
 SINCE 1954

1940 ALGONQUIN ROAD,
 SUITE 301
 CHARLESTON, SC 29405
 (843) 554-8602

| 5 | | | |
|-------------|----|----------|-------------------------|
| 4 | | | |
| 3 | | | |
| 2 | | | |
| 1 | | | |
| REV. NO. | BY | DATE | DESCRIPTION OF REVISION |
| DESIGNED BY | | DRAWN BY | CHECKED BY |

TOWN OF EDISTO BEACH

JUNGLE SHORES DR. AND DAWHOO ST. PATH UPGRADES PLAN SHEETS

SCALE 1" = 20' PLOT SIZE = 22" x 34"

| FED. ROAD DIV. NO. | STATE | COUNTY | ROAD NAME | ROUTE NO. | SHEET NO. | TOTAL SHEETS |
|--------------------|-------|----------|----------------------------------|-----------|-----------|--------------|
| 3 | S.C. | COLLETON | JUNGLE SHORES DR. AND DAWHOO ST. | | 8 | |

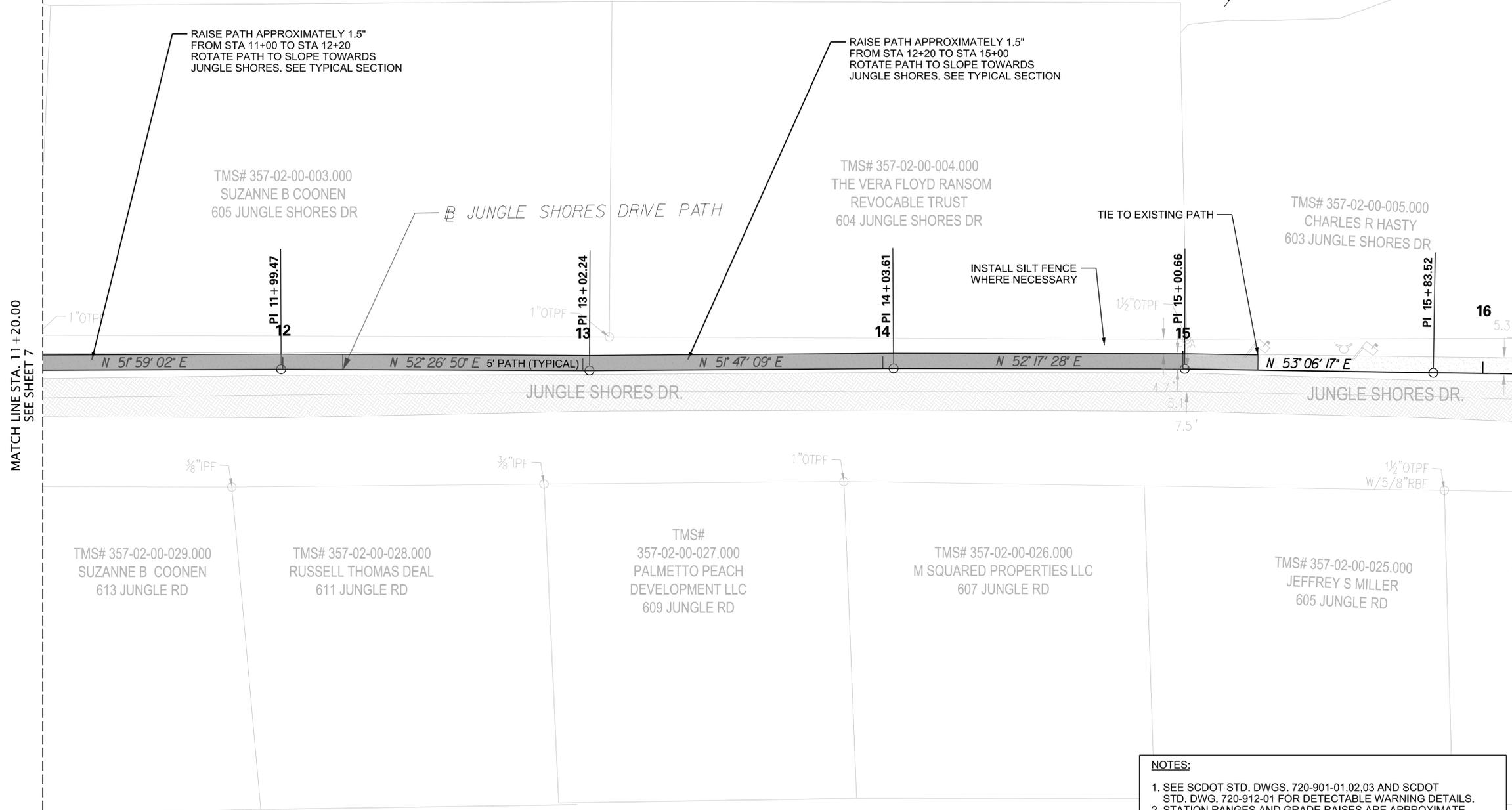

- NOTES:**
- SEE SCDOT STD. DWGS. 720-901-01.02,03 AND SCDOT STD. DWG. 720-912-01 FOR DETECTABLE WARNING DETAILS.
 - STATION RANGES AND GRADE RAISES ARE APPROXIMATE. CONTRACTOR TO VERIFY EXISTING CONDITIONS BEFORE CONSTRUCTION BEGINS.
 - CONTRACTOR SHALL PROVIDE A SMOOTH TRANSITION OVER A 25' MINIMUM LENGTH WHEN TYING TO EXISTING PATH.
 - CONTRACTOR TO COORDINATE WITH TOWN OF EDISTO BEACH TO RESOLVE CONFLICTS WITH WATER AND SEWER UTILITIES.
 - CONTRACTOR SHALL NOT WORK OUTSIDE OF EXISTING RIGHTS OF WAY.
 - RESET OR ADJUST MAILBOXES AS NECESSARY.
 - INSTALL SILT FENCE AS NECESSARY. SEE SCDOT STD. DWG 815-605-00 FOR DETAILS.

SCALE: 20,000 ft. / in.
 PEN TABLE: JUNGLE SHORES_PLANS.tbl
 PLOT DRIVER: PDF.plt
 FILE: G:\Jobs\006\31893-05\Production\Transportation\SHEETS\006_31893-05_PLAN SHEETS.DGN
 3/24/2025



FOR INFORMATION ONLY

DAVIS & FLOYD
 SINCE 1954

1940 ALGONQUIN ROAD,
 SUITE 301
 CHARLESTON, SC 29405
 (843) 554-8602

| 5 | | | |
|-------------|----|----------|-------------------------|
| 4 | | | |
| 3 | | | |
| 2 | | | |
| 1 | | | |
| REV. NO. | BY | DATE | DESCRIPTION OF REVISION |
| DESIGNED BY | | DRAWN BY | CHECKED BY |

TOWN OF EDISTO BEACH

JUNGLE SHORES DR. AND DAWHOO ST. PATH UPGRADES PLAN SHEETS

SCALE 1" = 20' PLOT SIZE = 22" x 34"

| FED. ROAD DIV. NO. | STATE | COUNTY | ROAD NAME | ROUTE NO. | SHEET NO. | TOTAL SHEETS |
|--------------------|-------|----------|----------------------------------|-----------|-----------|--------------|
| 3 | S.C. | COLLETON | JUNGLE SHORES DR. AND DAWHOO ST. | | 9 | |

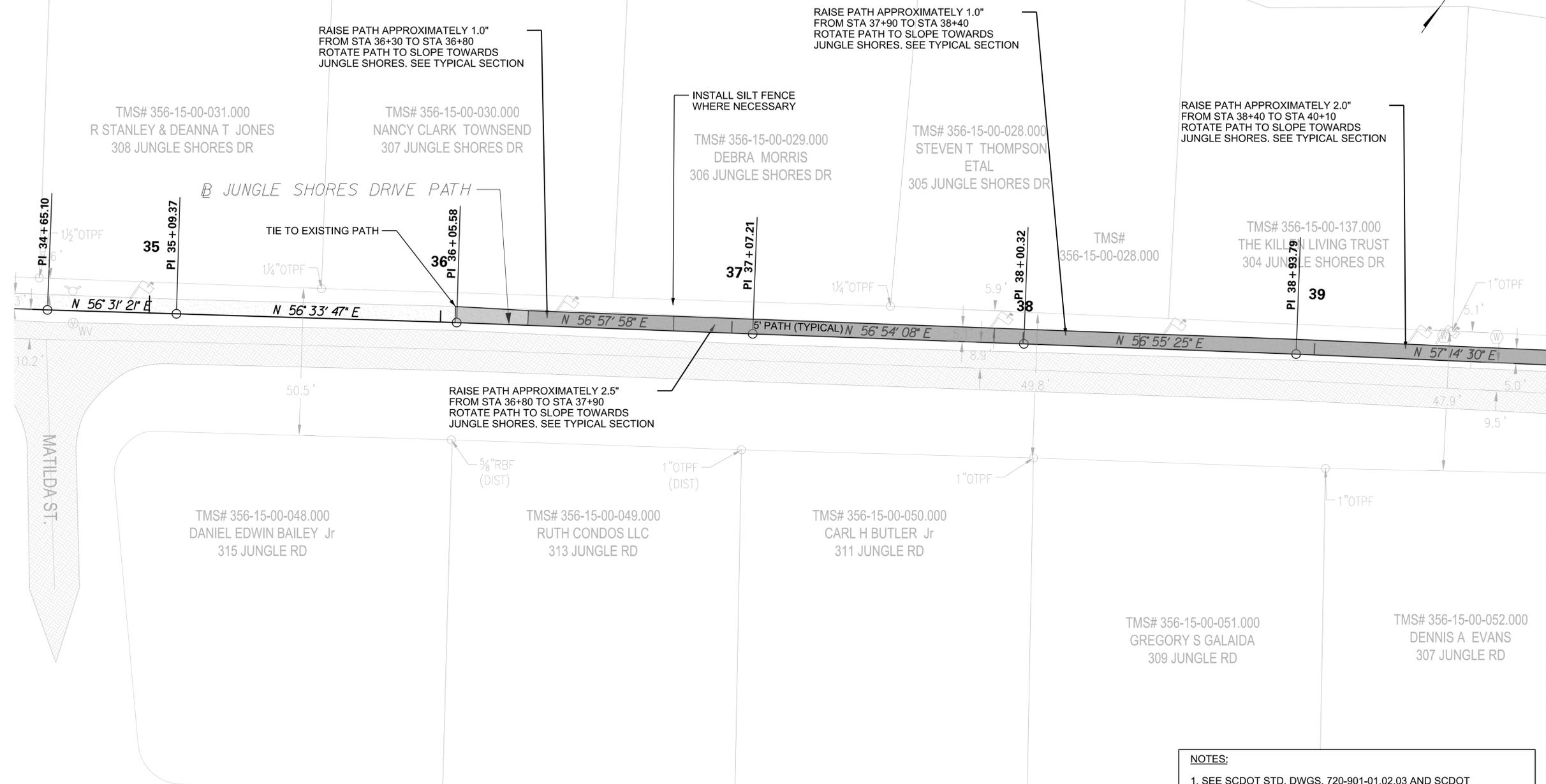
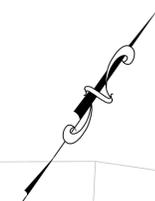

MATCH LINE STA. 39+80.00
SEE SHEET TO

- NOTES:**
- SEE SCDOT STD. DWGS. 720-901-01, 02, 03 AND SCDOT STD. DWG. 720-912-01 FOR DETECTABLE WARNING DETAILS.
 - STATION RANGES AND GRADE RAISES ARE APPROXIMATE. CONTRACTOR TO VERIFY EXISTING CONDITIONS BEFORE CONSTRUCTION BEGINS.
 - CONTRACTOR SHALL PROVIDE A SMOOTH TRANSITION OVER A 25' MINIMUM LENGTH WHEN TYING TO EXISTING PATH.
 - CONTRACTOR TO COORDINATE WITH TOWN OF EDISTO BEACH TO RESOLVE CONFLICTS WITH WATER AND SEWER UTILITIES.
 - CONTRACTOR SHALL NOT WORK OUTSIDE OF EXISTING RIGHTS OF WAY.
 - RESET OR ADJUST MAILBOXES AS NECESSARY.
 - INSTALL SILT FENCE AS NECESSARY. SEE SCDOT STD. DWG 815-605-00 FOR DETAILS.

SCALE: 20,000.00 ft. / in.
PEN TABLE: JUNGLE SHORES_PLANS.tbl
PLOT DRIVER: PDF.plt
FILE: G:\Jobs\001\31893-05\Production\Transportation\SHEETS\006_31893-05_PLAN_SHEETS.DGN
3/24/2025

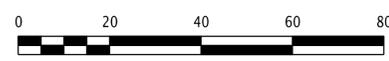

FOR
INFORMATION
ONLY

DAVIS & FLOYD

SINCE 1954

1940 ALGONQUIN ROAD,
SUITE 301
CHARLESTON, SC 29405
(843) 554-8602

| 5 | | | |
|-------------|----|----------|-------------------------|
| 4 | | | |
| 3 | | | |
| 2 | | | |
| 1 | | | |
| REV. NO. | BY | DATE | DESCRIPTION OF REVISION |
| DESIGNED BY | | DRAWN BY | CHECKED BY |

TOWN OF EDISTO BEACH

JUNGLE SHORES DR. AND
DAWHOO ST. PATH UPGRADES
PLAN SHEETS

SCALE 1" = 20' PLOT SIZE = 22" x 34"

| FED. ROAD DIV. NO. | STATE | COUNTY | ROAD NAME | ROUTE NO. | SHEET NO. | TOTAL SHEETS |
|--------------------|-------|----------|----------------------------------|-----------|-----------|--------------|
| 3 | S.C. | COLLETON | JUNGLE SHORES DR. AND DAWHOO ST. | | 10 | |

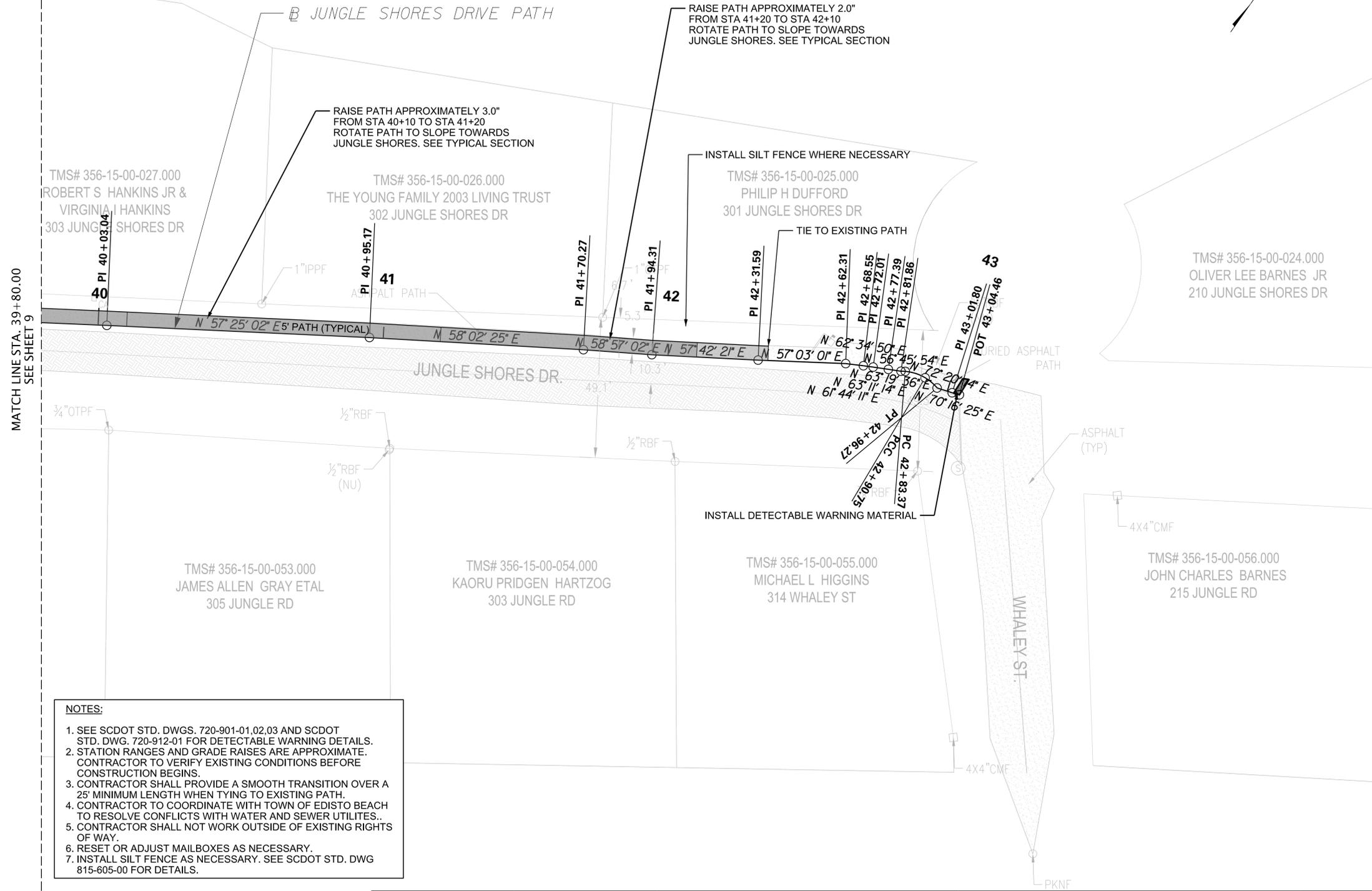
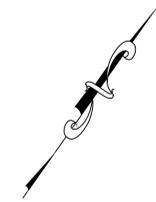

- NOTES:**
1. SEE SCDOT STD. DWGS. 720-901-01,02,03 AND SCDOT STD. DWG. 720-912-01 FOR DETECTABLE WARNING DETAILS.
 2. STATION RANGES AND GRADE RAISES ARE APPROXIMATE. CONTRACTOR TO VERIFY EXISTING CONDITIONS BEFORE CONSTRUCTION BEGINS.
 3. CONTRACTOR SHALL PROVIDE A SMOOTH TRANSITION OVER A 25' MINIMUM LENGTH WHEN TYING TO EXISTING PATH.
 4. CONTRACTOR TO COORDINATE WITH TOWN OF EDISTO BEACH TO RESOLVE CONFLICTS WITH WATER AND SEWER UTILITIES.
 5. CONTRACTOR SHALL NOT WORK OUTSIDE OF EXISTING RIGHTS OF WAY.
 6. RESET OR ADJUST MAILBOXES AS NECESSARY.
 7. INSTALL SILT FENCE AS NECESSARY. SEE SCDOT STD. DWG 815-605-00 FOR DETAILS.

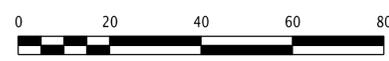

**FOR
INFORMATION
ONLY**

DAVIS & FLOYD
SINCE 1954

1940 ALGONQUIN ROAD,
SUITE 301
CHARLESTON, SC 29405
(843) 554-8602

| 5 | | | |
|-------------|----|----------|-------------------------|
| 4 | | | |
| 3 | | | |
| 2 | | | |
| 1 | | | |
| REV. NO. | BY | DATE | DESCRIPTION OF REVISION |
| DESIGNED BY | | DRAWN BY | CHECKED BY |

TOWN OF EDISTO BEACH

JUNGLE SHORES DR. AND
DAWHOO ST. PATH UPGRADES
PLAN SHEETS

SCALE 1" = 20' PLOT SIZE = 22" x 34"

SCALE: 20,000 ft. / in.
 PEN TABLE: JUNGLE SHORES_PLANS.tbl
 PLOT DRIVER: PDF.plt
 FILE: G:\Jobs\05\1893-05\Production\Transportation\SHEETS\006_31893-05_PLAN SHEETS.DGN
 3/24/2025